

# All-solid-state batteries: an overview for bio applications

R. Sousa

Algoritmi Centre: Industrial Electronics Department  
University of Minho  
Guimarães, Portugal  
[rmsousa@dei.uminho.pt](mailto:rmsousa@dei.uminho.pt)

J.A. Sousa

Industrial Electronics Department  
University of Minho  
Guimarães, Portugal  
[a48035@alunos.uminho.pt](mailto:a48035@alunos.uminho.pt)

J.F. Ribeiro

Algoritmi Centre: Industrial Electronics Department  
University of Minho  
Guimarães, Portugal  
[jribeiro@dei.uminho.pt](mailto:jribeiro@dei.uminho.pt)

L.M. Goncalves

Algoritmi Centre: Industrial Electronics Department  
University of Minho  
Guimarães, Portugal  
[lgoncalves@dei.uminho.pt](mailto:lgoncalves@dei.uminho.pt)

J.H. Correia

Algoritmi Centre: Industrial Electronics Department  
University of Minho  
Guimarães, Portugal  
[higino.correia@dei.uminho.pt](mailto:higino.correia@dei.uminho.pt)

**Abstract** — Batteries are crucial for most of bio applications. Batteries based on a liquid or polymer electrolyte needs a weight protective packaging which decreases their energy density and increases their size. This paper aims to identify, on the one hand, the efforts performed in thin-film batteries until now, and on the other hand, to provide an overview about the future perspectives in integration of batteries with flexible electronic circuits and energy harvesting systems. The overview highlights the need for an on-going investigation that aims to replace metallic lithium anode of batteries through different approaches. Other materials, namely silicon or germanium, seem promising when combined with nanostructures. Three dimensional and integrated batteries will increase its volumetric capacity.

**Keywords** — *all-solid-state batteries; bio applications; integration, overview.*

## I. INTRODUCTION

Nowadays, the diversity of electronic autonomous and portable devices requires on board energy. Batteries convert chemical energy into electric energy, which increases the volumetric energy density, when compared with capacitors. Many of these devices rely on rechargeable batteries since can delivery higher volumetric and gravimetric energy densities [1]. In figure 1 is compared the battery capacity for different technologies, namely, conventional lithium-ion batteries (Li-ion), batteries based on polymer lithium electrolyte (Li-polymer) and also lithium-ion batteries in thin-films (Film Li/Li-ion).

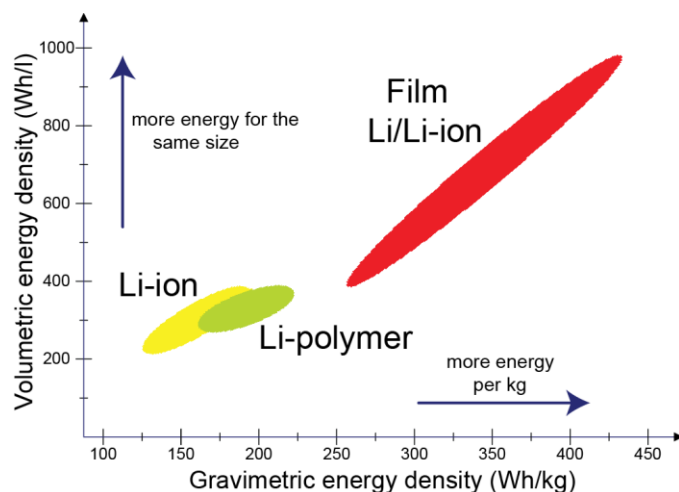

Figure 1: Battery capacity for different technologies [2].

Conventional lithium-ion batteries use a liquid electrolyte and polymer lithium batteries use a polymer-based electrolyte. This implies a hermetically and heavy packaging which increase batteries weight and decreases their energy density. Furthermore, the use of liquid/polymer electrolytes, create several safety issues, like leaking, becoming crucial the emergence and continuous development of all-solid-state batteries due to the rigid safety requirements for bio applications. Taking advantage of weight and size reduction with batteries fabricated only by thin-films opens up the

opportunity of devices miniaturization and, at the same time and most importantly, the integration of micro/nano batteries directly into the electronic chips [3]. In the present research our aim is to integrate batteries, energy harvesting systems and electronic circuits with MPPT algorithms, at the same substrate, that can be flexible. Therefore, our broader purpose is to enable the supplying of electrical energy in sensing and monitoring applications for autonomous wireless microsystems. Human body applications and other bio applications can benefit of these characteristics.

## II. BATTERIES WORKING PRINCIPLE

A battery is composed by two electrodes and one electrolyte between them, acting as an electrical isolator. In the positive electrode, cathode, reduction reactions occurs, and in the negative electrode, anode, the oxidation reactions takes place. The anode in lithium batteries is normally composed by metallic lithium. The electrolyte ensures the isolation among cathode and anode allowing the exchange of lithium-ions through it. Thus, the main features of an electrolyte must be excellent ionic conductivity; high electric resistivity, forcing the movement of electrons through an external circuit and good adhesion with the electrodes. Furthermore, an electrolyte must be electrochemical stable for the range voltage of battery. Figure 2 represents a schematic of a typical planar all-solid-state battery.

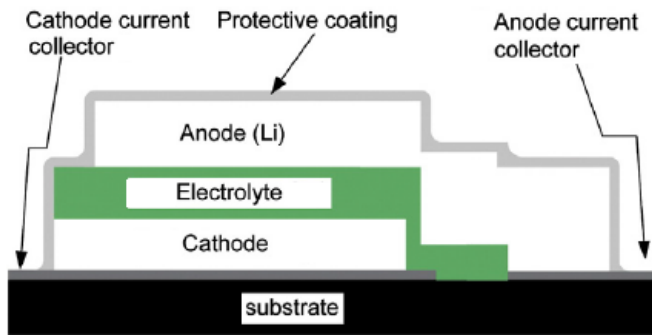

Figure 2: Schematic of a typical planar all-solid-state battery with a lithium metal anode [4].

All-solid-state batteries had already been under extensive investigation and development using Physical Vapor Deposition Techniques (PVD) [5–8]. Nowadays some of them are commercially available at companies like *Cymbet* (ORNL technology), *Infinite Power Solutions* and *Front Edge*. Others companies like *Sakti3*, *Seeo*, *Toyota/AIST*, *Excellatron* and *Planar Energy* are developing their products to briefly start its commercialization.

The operating voltage, in lithium batteries, is defined through chemical composition of their electrodes, cathode and anode, and aren't related with their dimensions, which affects the batteries capacity.

During the charge of a battery, lithium ions are extracted from cathode to anode through electrolyte and electrons by

external circuit. Conversely, during the discharge, the reverse process occurs with cathode receiving lithium ions internally and electrons externally. Figure 3 illustrates the battery charge/discharge with Li ions passing through the electrolyte and electrons passing through the lamp.

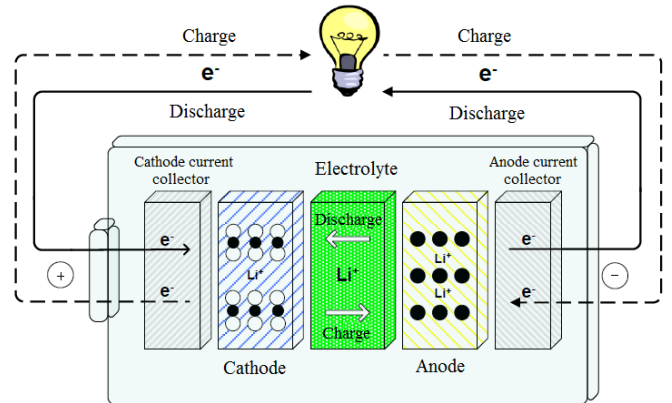

Figure 3: Representation of a battery charge/discharge [9].

The cathode and anode current collectors, platinum and titanium, respectively, are deposited by e-beam technique. The most common cathode of a thin-film battery is lithium cobalt oxide ( $\text{LiCoO}_2$ ) and the electrolyte is lithium phosphorus oxynitride ( $\text{LiPON}$ ), both deposited by RF sputtering. Within the scope of the present research, extensive investigation have been developed in order to improved and achieve better characteristics for these two materials [4][10].

Promising results have been achieved, in our study, using the electrodes and electrolyte materials mentioned above. Figure 4 presents a thin film lithium-ion battery made on a flexible substrate.

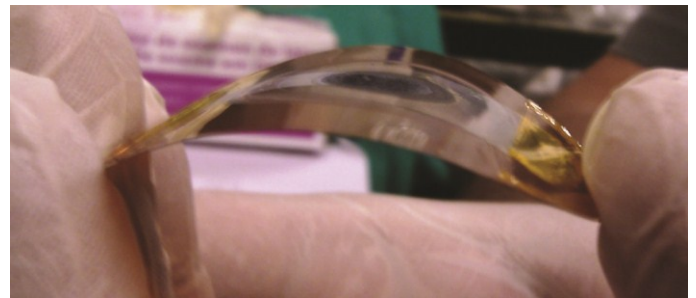

Figure 4: Thin-film lithium-ion battery fabricated on flexible substrate.

This battery presents yet a low capacity. Figure 5 illustrates the capacity obtained in charge curves for ten charge/discharge cycles. The charge was performed applying a constant current of 10 nA to the battery, until a voltage of 3.9 V was achieved. A gradual loss of capacity is revealed with decreasing of charge times along charge/discharge cycles.

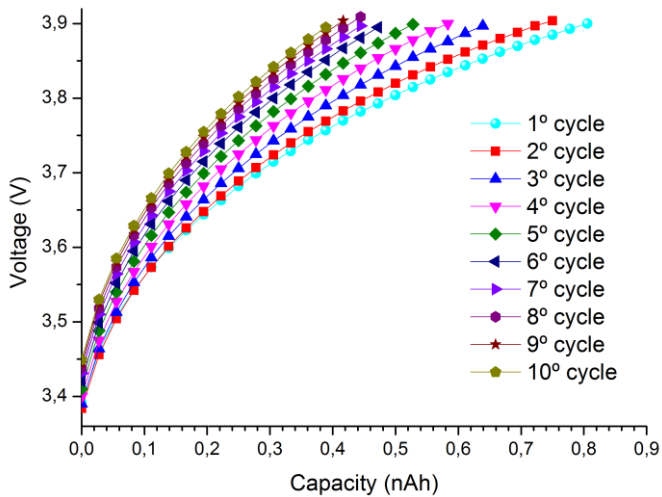

Figure 5: Capacity of the battery in charge curves for ten charge/discharge cycles applying a current of 10 nA.

### III. CHALLENGES FOR FUTURE PLANAR BATTERIES

Despite the high gravimetric capacity of lithium, 3860 mAh/g, and lower molecular weight, lithium has several drawbacks. One of them is its low melting point temperature, around 180 °C, incompatible with the solder process in microelectronic industry. Another one is its high reactivity, especially when in contact with water and air, turning inflammable and explosive and therefore implying the use of effective protective coatings, like silicon nitride [11], layers of different materials [2] and interspersed layers of Ti and parylene C [12]. Moreover the formation of dendrites in the interface among electrolyte and anode, due to continuous cycles of charge/discharge, resulting in a chemical inactivity of anode, is another drawback of metallic lithium as anode [13].

Therefore, several studies, including the present investigation, are looking for other materials to replace the metallic lithium, such as, tin (Sn), silicon (Si) and germanium (Ge), among others. Results showing that anode based on Sn films reveals a decreasing of their gravimetric capacity, 560 mAh/g, after a few cycles of charge/discharge [14]. Silicon based anode presents a high gravimetric capacity, 4200 mAh/g, with the formation of  $\text{Li}_{4.4}\text{Si}$  [15]. However, this unbalance provokes large volume variations until 300% leaving to film destruction [16]. Germanium films have a diffusion coefficient of lithium ions two orders of magnitude higher than silicon and supports better the volume variations during the insertion and extraction of lithium ions. Results reveal a gravimetric capacity nearby of 1600 mAh/g [17]. According to these results silicon and germanium emerge as the more promising materials to substitute metallic lithium in thin-film batteries. Therefore, they will be used in the current investigation.

Further approaches are in investigation namely carbon, graphene and germanium nanotubes [18], nanostructures of Sn and Si (like honeycombs, nanotubes, nanowires, nanofibers or porous films) [19], composites of Sn-based [20] and Si-based [16], among others. Lithium-free batteries constitute a different

approach to replace the lithium anode where the anode is itself its own current collector, normally copper [13].

### IV. THREE DIMENSIONAL BATTERIES

A different approach, than planar batteries, are the three dimensional batteries. One of the ways to increase the volumetric capacity of batteries is increasing the contact area between cathode, electrolyte and anode, allowing faster charge/discharge times.

H.-S. Min, *et al.* [21] uses lithography, pyrolysis and electrodeposition techniques to create micro-rods or micro-stems on two separate contacts pads, represented in figure 6. A half of the micro-rods are used as cathode and the other half as anode. This approach presents some advantages since both electrodes have their current collectors integrated, allowing electrodeposition. The micro-rods can be used directly as anode and offers large versatility on his design. Nevertheless, a solid electrolyte deposition becomes difficult with PVD techniques in order to guarantee a uniform layer with good contact between electrodes.

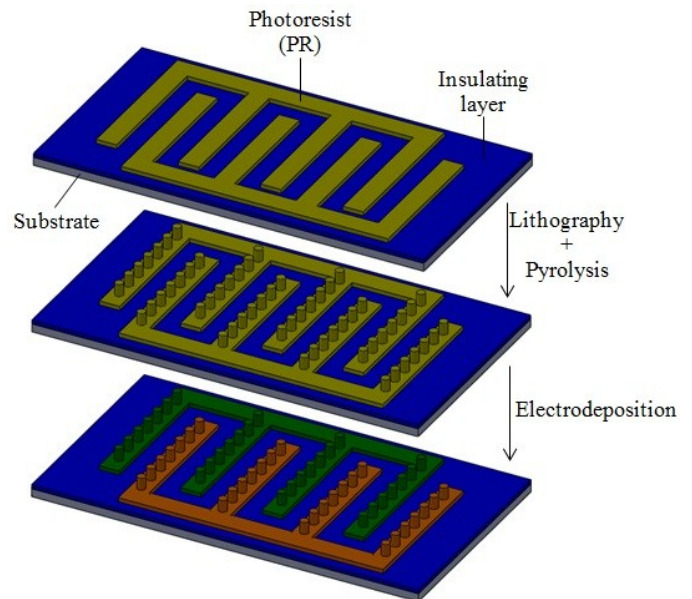

Figure 6: Three dimensional micro-rods or micro-stems structure [22].

An alternative and recent structure is a trench configuration, integrated on a silicon wafer using reactive ion etching (RIE) [23]. The main advantages are the better accommodations of volume variations during charge/discharge cycles, the uses of Si as anode material to replace metallic lithium and the good knowledge in integrated circuit (IC) technologies allows the integration and miniaturization of microsystems. However, as drawbacks, this alternative implies an effective lithium barrier layer among substrate and active materials, the possible secondary reactions which can increase the self-discharge rate and the difficulty to obtain a homogeneously layers by accessible deposition techniques, like PVD [23]. Figure 7 shows a schematic representation of a three dimensional integrated all-solid-state battery.

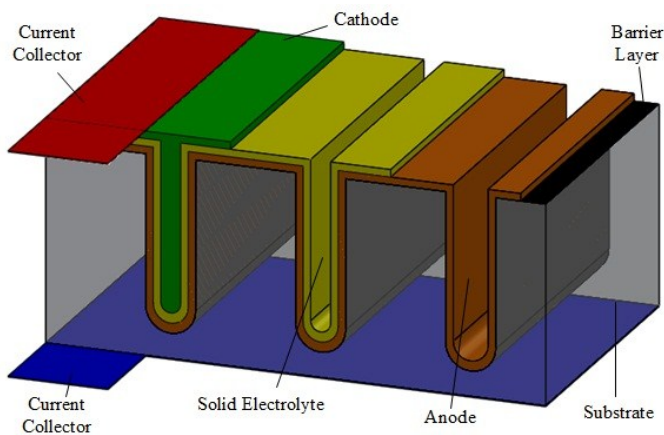

Figure 7: Schematic representation of a three dimensional integrated all-solid-state battery with a trench configuration [24].

## V. SUMMARY AND OUTLOOK

Research around all-solid-state batteries reveals crucial for miniaturization and integration of several autonomous devices [25], especially in bio devices. In this study the first problem in batteries was exposed as being the use of a liquid electrolyte which imposed rigid safety requirements in protective packaging. Consequently researchers have focused on this part and obtain a solid electrolyte with good properties. Currently, the direction of research is replacing the anode using nanostructures of silicon, germanium among others materials.

The thin film battery build in a flexible substrate, presented in this work, can be adapted of any surface ensuring the self-sufficiency of autonomous devices. Matching three dimensional and integrated batteries in flexible substrate with energy harvesting systems, like solar cells, and with electronics circuits a new vision of the future autonomous devices is being drawing.

## ACKNOWLEDGMENT

This work was financial supported by FCT funds with the project PTDC/EEAELC/114713/2009, with second author scholarship SFRH/BD/78217/2011 and strategic project from Algoritmi Centre FCOMP-01-0124-FEDER-022674.

## REFERENCES

- [1] J.-M. Tarascon and M. Armand, "Issues and challenges facing rechargeable lithium batteries.," *Nature*, vol. 414, no. 6861, pp. 359–67, Nov. 2001.
- [2] J. F. Ribeiro, R. Sousa, J. A. Sousa, B. M. Pereira, M. F. Silva, L. M. Goncalves, M. M. Silva, and J. H. Correia, "Rechargeable lithium film batteries – encapsulation and protection," *Procedia Engineering*, vol. 47, pp. 676–679, Jan. 2012.
- [3] J. P. Carmo, L. M. Goncalves, and J. H. Correia, "Thermoelectric microconverter for energy harvesting systems," *IEEE Transactions on Industrial Electronics*, vol. 57, no. 3, pp. 861–867, Mar. 2010.
- [4] J. F. Ribeiro, R. Sousa, J. P. Carmo, L. M. Goncalves, M. F. Silva, M. M. Silva, and J. H. Correia, "Enhanced solid-state electrolytes made of lithium phosphorous oxynitride films," *Thin Solid Films*, vol. 522, pp. 85–89, Sep. 2012.

- [5] J. B. Bates, N. J. Dudney, D. C. Lubben, G. R. Gruzalski, B. S. Kwak, X. Yu, and R. A. Zuhr, "Thin-film rechargeable lithium batteries," *Journal of Power Sources*, vol. 54, no. 1, pp. 58–62, Mar. 1995.
- [6] J. B. Bates, N. J. Dudney, B. Neudecker, A. Ueda, and C. D. Evans, "Thin-film lithium and lithium-ion batteries," *Solid State Ionics*, vol. 135, no. 1–4, pp. 33–45, Nov. 2000.
- [7] N. J. Dudney, J. B. Bates, and B. J. Neudecker, "Thin-film materials for solid-state rechargeable batteries," *Encyclopedia of Materials: Science and Technology*, pp. 9302–9306, 2001.
- [8] B. Fleutot, B. Pecquenard, F. Le Cras, B. Delis, H. Martinez, L. Dupont, and D. Guy-Bouyssou, "Characterization of all-solid-state Li/LiPONB/TiOS microbatteries produced at the pilot scale," *Journal of Power Sources*, vol. 196, no. 23, pp. 10289–10296, Dec. 2011.
- [9] J. F. Ribeiro, "Deposição e caracterização de filmes finos para baterias de lítio em estado sólido," University of Minho, 2010.
- [10] J. F. Ribeiro, M. F. Silva, L. M. Goncalves, J. P. Carmo, J. H. Correia, M. M. Silva, F. Cerqueira, and P. Alpuim, "Thin-film solid-state rechargeable lithium battery," in *MME*, 2011, no. Li, pp. 190–193.
- [11] P. Alpuim, L. M. Goncalves, E. S. Marins, T. M. R. Viseu, S. Ferdov, and J. E. Bourée, "Deposition of silicon nitride thin films by hot-wire CVD at 100 °C and 250 °C," *Thin Solid Films*, vol. 517, no. 12, pp. 3503–3506, Apr. 2009.
- [12] N. J. Dudney, "Solid-state thin-film rechargeable batteries," *Materials Science and Engineering: B*, vol. 116, no. 3, pp. 245–249, Feb. 2005.
- [13] T. Minami, M. Tatsumisago, M. Wakihara, C. Iwakura, S. Kohjiya, and I. Tanaka, *Solid state ionics for batteries*. Tokyo: Springer, 2005, p. 271.
- [14] P. G. Bruce, B. Scrosati, and J.-M. Tarascon, "Nanomaterials for rechargeable lithium batteries," *Angewandte Chemie*, vol. 47, no. 16, pp. 2930–46, Jan. 2008.
- [15] Y. E. Roginskaya, T. L. Kulova, A. M. Skundin, M. A. Bruk, E. N. Zhikharev, and V. A. Kal'nov, "Lithium insertion into silicon films produced by magnetron sputtering," *Russian Journal of Electrochemistry*, vol. 44, no. 9, pp. 992–1001, Sep. 2008.
- [16] K. E. Aifantis, S. A. Hackney, and R. V. Kumar, *High energy density lithium batteries*. Weinheim, Germany: Wiley-VCH Verlag GmbH & Co. KGaA, 2010, p. 257.
- [17] B. Laforge, L. Levan-Jodin, R. Salot, and A. Billard, "Study of germanium as electrode in thin-film battery," *Journal of The Electrochemical Society*, vol. 155, no. 2, p. A181, 2008.
- [18] G. Du, "Nanostructured anode materials for lithium-ion batteries," University of Wollongong, 2011.
- [19] J. Wang, Y. Chen, and L. Qi, "The development of silicon nanocomposite materials for Li-ion secondary batteries," *Open Materials Science Journal*, vol. 5, no. 1, pp. 228–235, 2011.
- [20] J. Seo, J. Jang, S. Park, C. Kim, B. Park, and J. Cheon, "Two-dimensional SnS<sub>2</sub> nanoplates with extraordinary high discharge capacity for lithium ion batteries," *Advanced Materials*, vol. 20, no. 22, pp. 4269–4273, Nov. 2008.
- [21] H.-S. Min, B. Y. Park, L. Taherabadi, C. Wang, Y. Yeh, R. Zaouk, M. J. Madou, and B. Dunn, "Fabrication and properties of a carbon/polypyrrole three-dimensional microbattery," *Journal of Power Sources*, vol. 178, no. 2, pp. 795–800, Apr. 2008.
- [22] J. F. M. Oudenhoven, "Deposition and Characterization of Thin Films for 3D Lithium-ion Micro-Batteries," Eindhoven University of Technology, 2011.
- [23] P. H. L. Notten, F. Roozeboom, R. A. H. Niessen, and L. Baggetto, "3-D integrated all-solid-state rechargeable batteries," *Advanced Materials*, vol. 19, no. 24, pp. 4564–4567, Dec. 2007.
- [24] L. Baggetto, R. A. H. Niessen, F. Roozeboom, and P. H. L. Notten, "High energy density all-solid-state batteries: a challenging concept towards 3D integration," *Advanced Functional Materials*, vol. 18, no. 7, pp. 1057–1066, Apr. 2008.
- [25] A. Brazier, L. Dupont, L. Dantras-Laffont, N. Kuwata, J. Kawamura, and J.-M. Tarascon, "First cross-section observation of an all solid-state lithium-ion 'nanobattery' by transmission electron microscopy," *Chemistry of Materials*, vol. 20, no. 6, pp. 2352–2359, Mar. 2008.